

ASSEMBLED CONSOLE

/32 SIZE SHOWN

REV.	ZONE	DESCRIPTION	NAME/DATE
B	ALL	ADDED NOTES AND DIMENSIONS	OG 05/23/06
C	/40 ASSEMBLY	CHANGED NUMBER OF CONNECTORS FOR LAMP SOCKETS FROM 3 TO 4	OG 08/28/07

FRONT VIEW

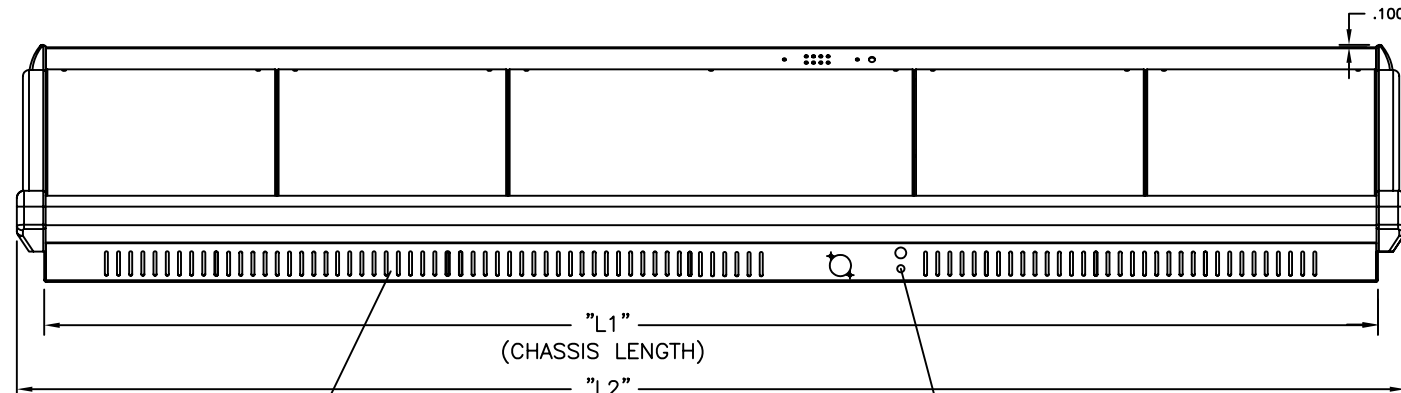

RIGHT SIDE VIEW

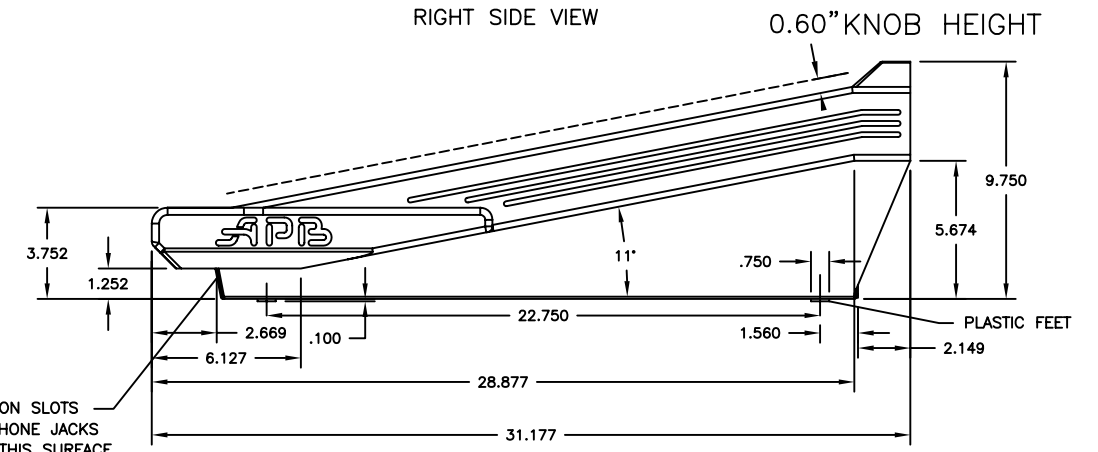

SECTION A-A

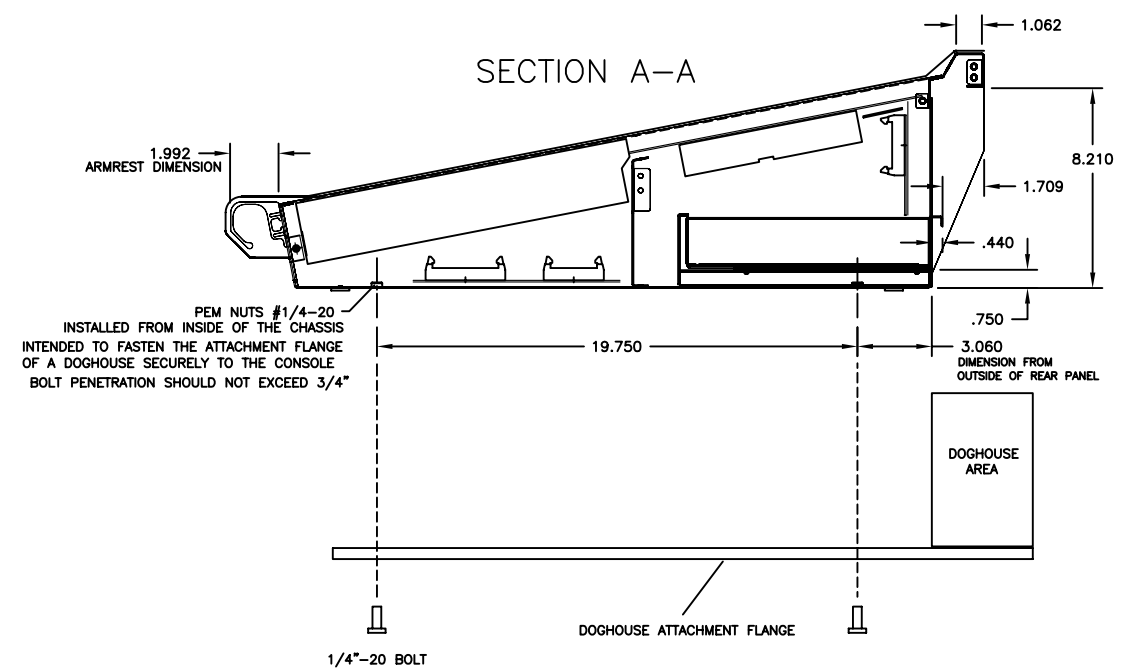

TOP VIEW

4-PIN XLR LAMP SOCKETS
LOCATED ALONG REAR FACE OF THIS TOP RAIL
(SEE SHEET 3, 4 AND 5 FOR LOCATION PER SIZE)

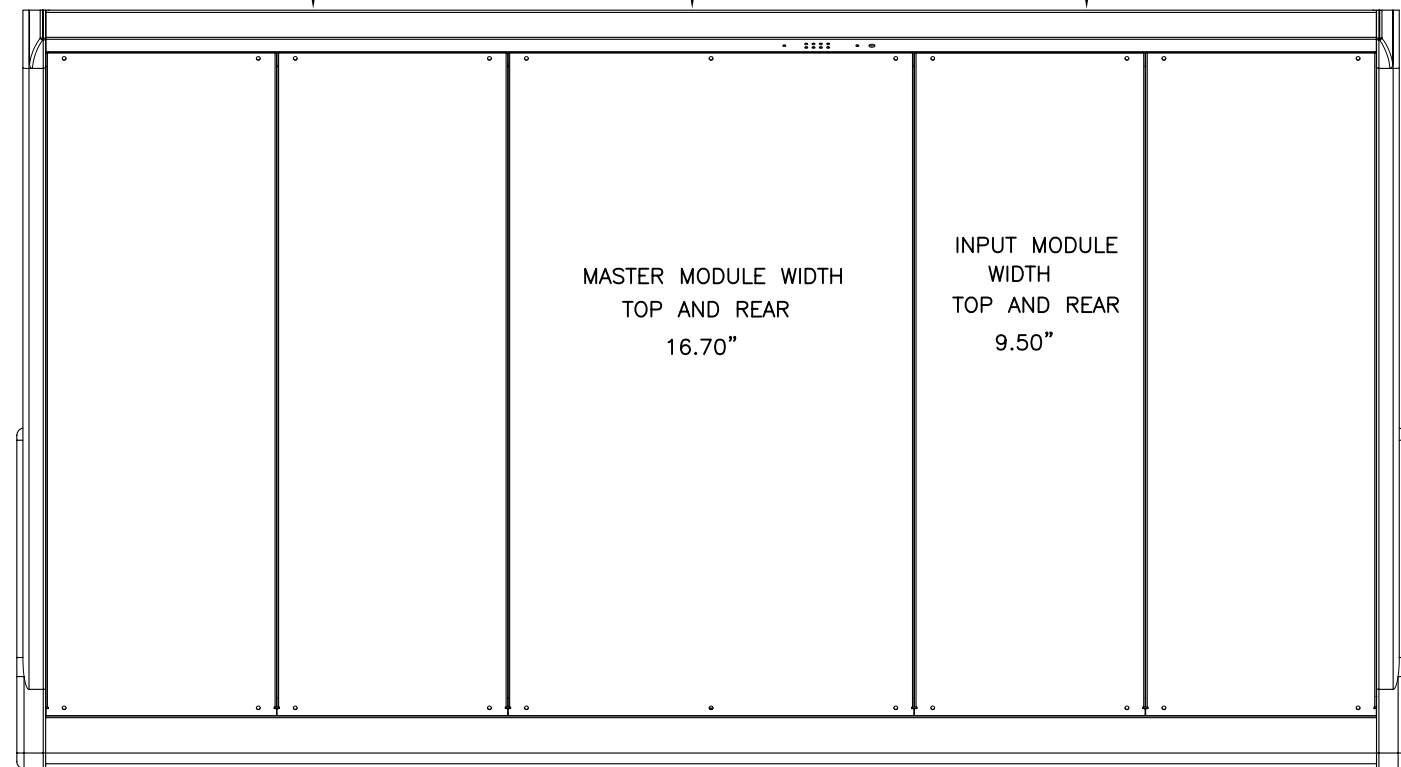

VARIABLE LENGTH PER CHASSIS SIZE

SIZE LENGTH"	EXP	/24	/32	/40	/48	/56
"L1"	28.7	45.32	54.82	64.32	73.82	83.32
"L2"	30.87	47.57	57.07	66.57	76.07	85.57

APB - DynaSonics, Inc. 20 West End Road Totowa, NJ 07512		Title: SPECTRA SERIES CONSOLE CHASSIS ASSEMBLY INFORMATION FOR ROAD CASE DESIGN	
Dr.By: OG	Date: 04/20/05	APB P/N:	
Chk.By:	Date:	Scale:	Dwg#: 4D0118
App.By:	Date:	DO NOT SCALE DRAWING	
Tolerance: .xx: +/- .02 .xxx: +/- .01 <+/-1	Material:	Finish:	Rev.: C
			Sheet: 1 OF 5

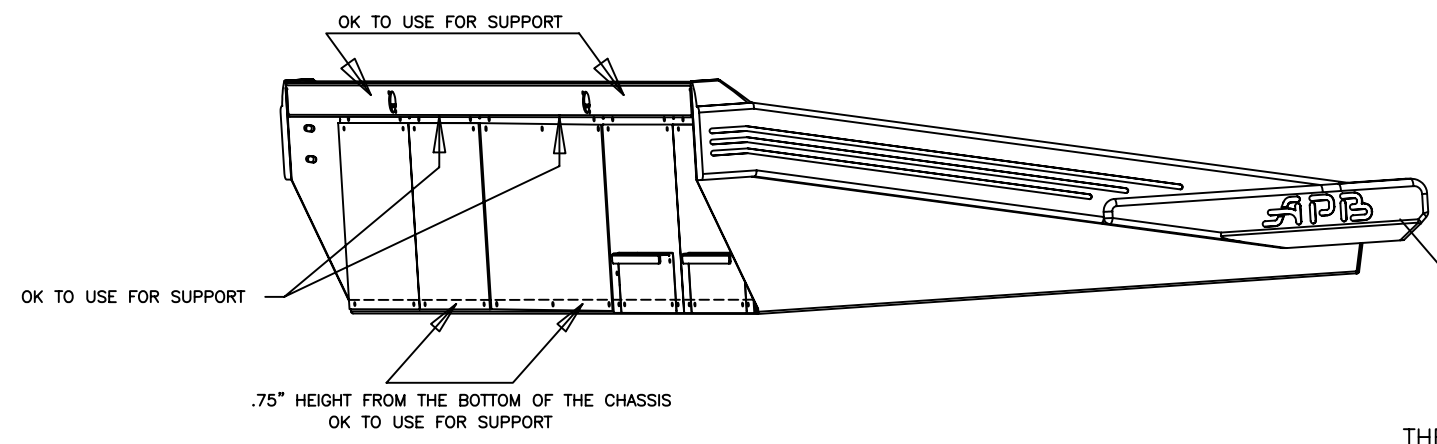
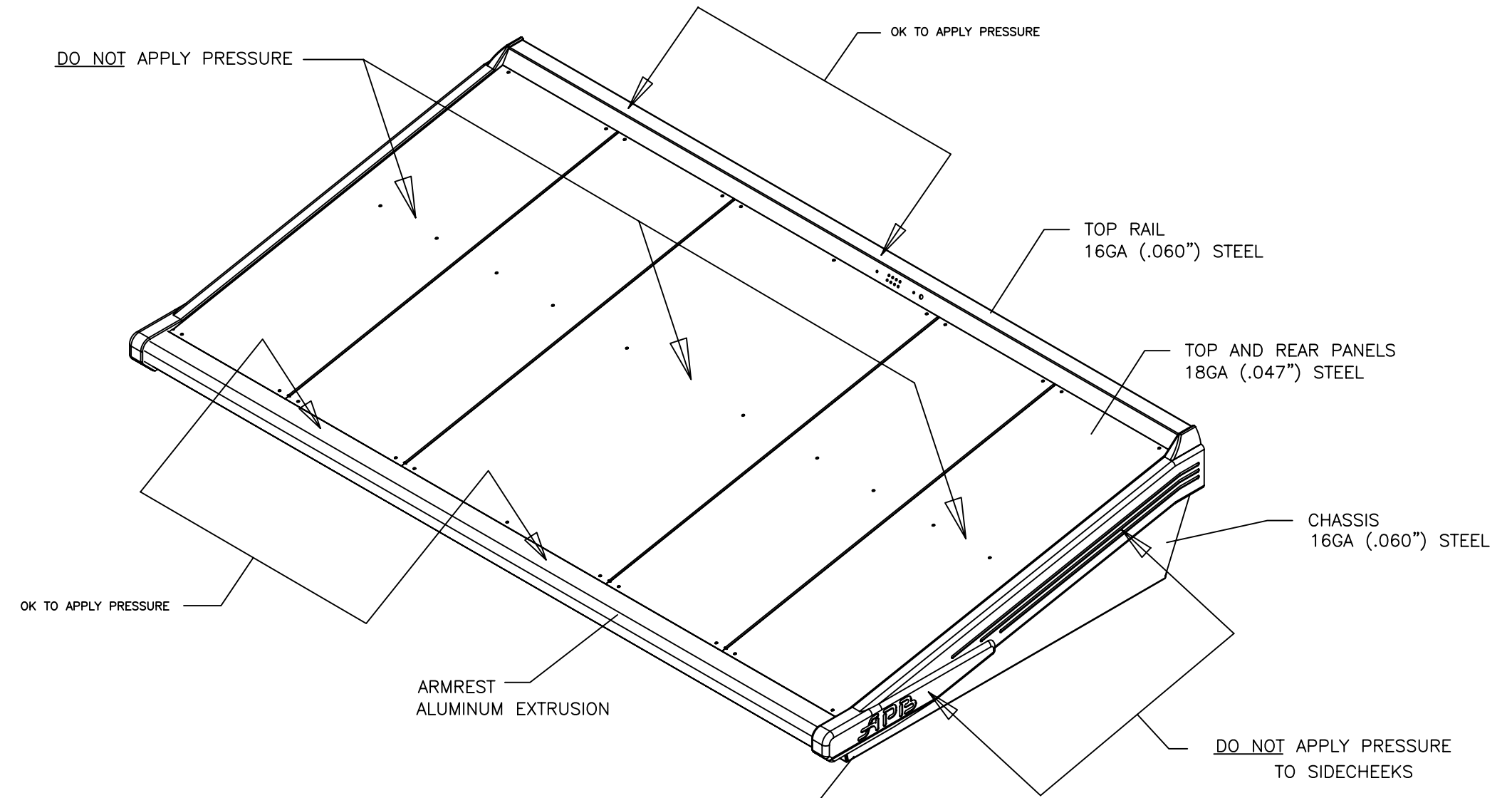

THESE SIDECHEEKS ARE COSMETIC PARTS AND SHOULD NOT TO BE USED TO SUPPORT THE CONSOLE WHILE IN A ROADCASE OR DURING USE

			Title: SPECTRA SERIES CONSOLE CHASSIS ASSEMBLY INFORMATION FOR ROAD CASE DESIGN	
Dr.By: OG	Date: 04/20/05	APB P/N:		Dwg#: 4D0118
Chk.By:	Date:	Scale:	Rev.: C	
App.By:	Date:	DO NOT SCALE DRAWING		Sheet: 2 OF 5
Tolerance: .xx: +/- .02 .xxx: +/- .01 <+/-1	Material:	Finish:		

/32 ASSEMBLY
REAR VIEW

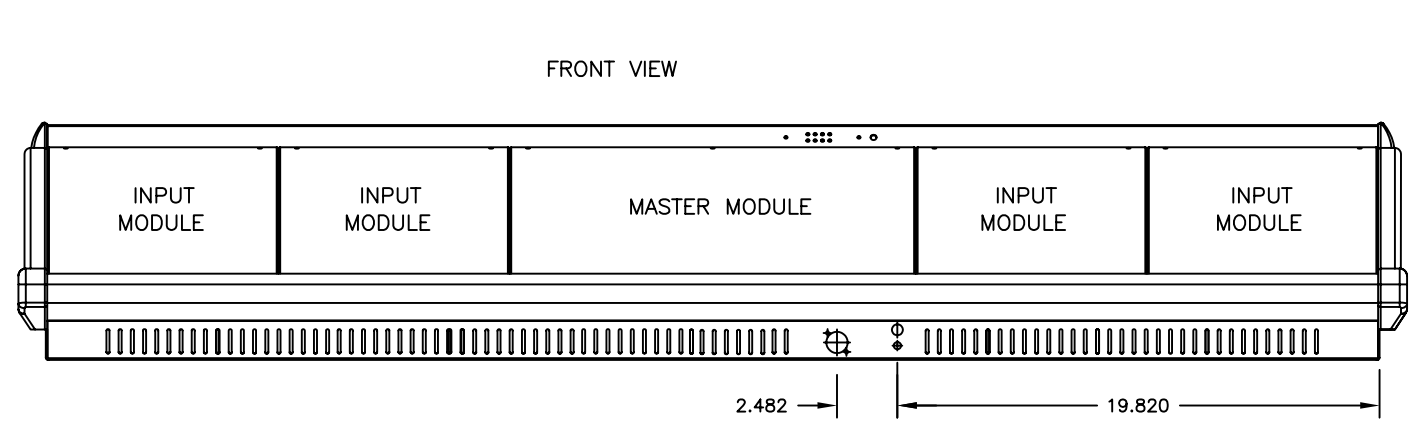
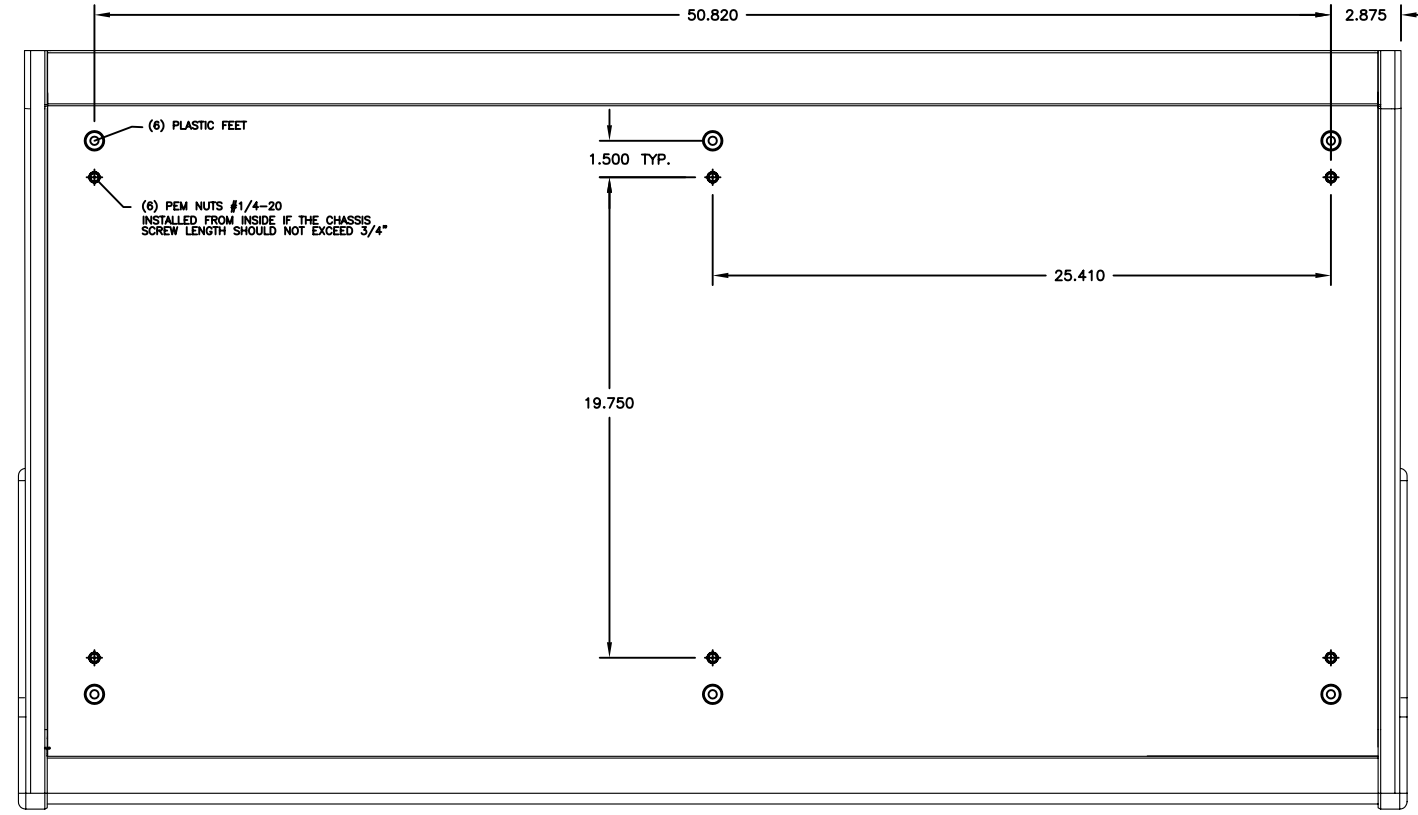
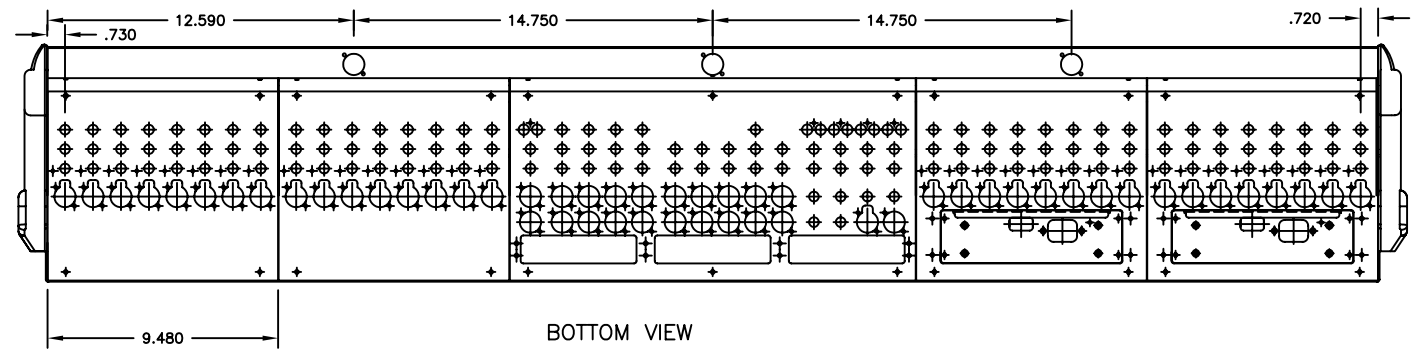

/40 ASSEMBLY
REAR VIEW

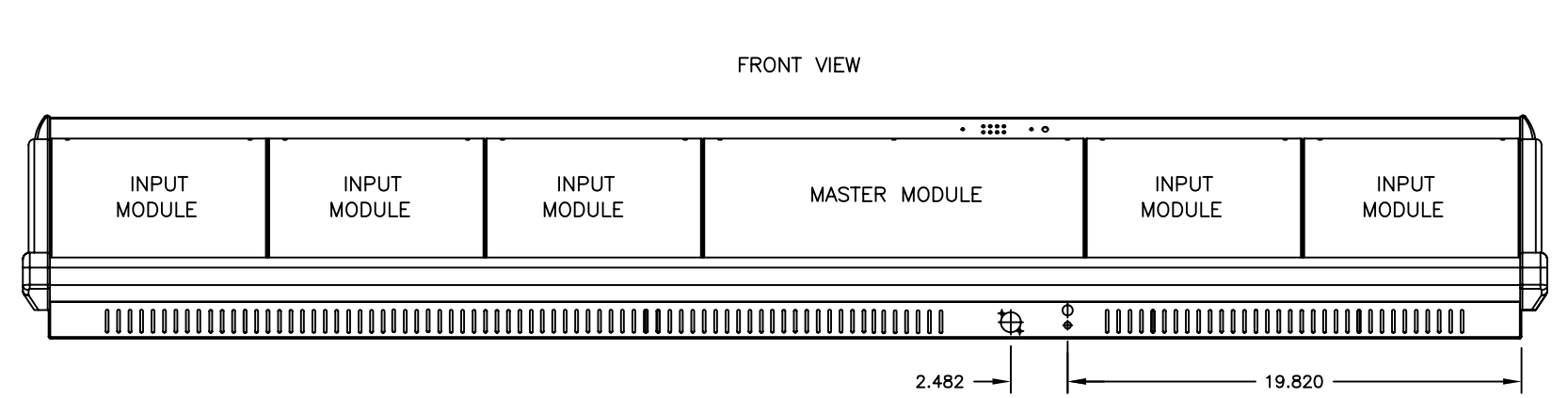
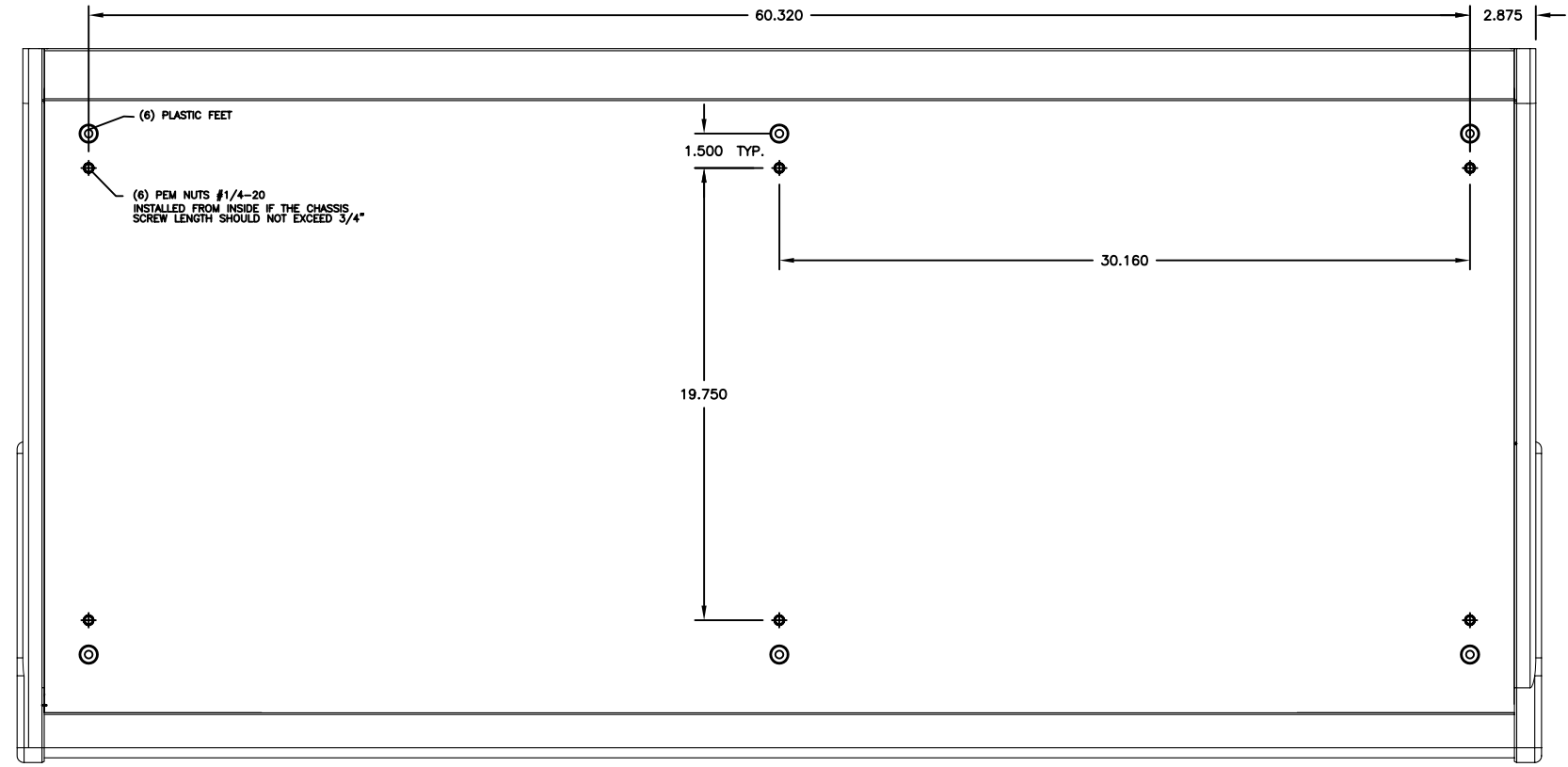
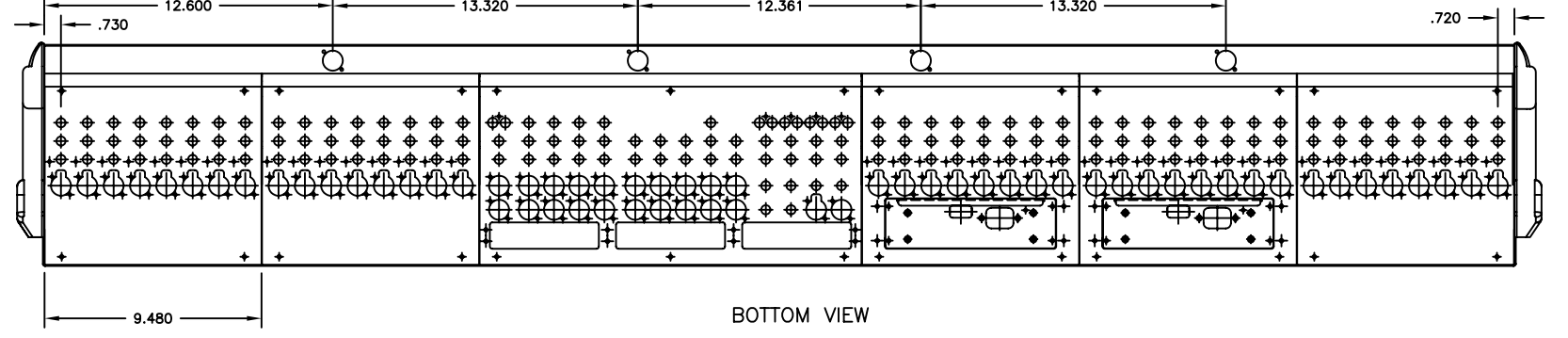

			Title: SPECTRA SERIES CONSOLE CHASSIS ASSEMBLY INFORMATION FOR ROAD CASE DESIGN	
Dr. By: OG	Date: 04/20/05	APB P/N:	Dwg#: 4D0118	Rev.: C
Chk. By:	Date:	Scale:		
App. By:	Date:	DO NOT SCALE DRAWING	Sheet: 3 OF 5	
Tolerance: XX: +/- .02 .XXX: +/- .01 <+/-1"	Material:	Finish:		

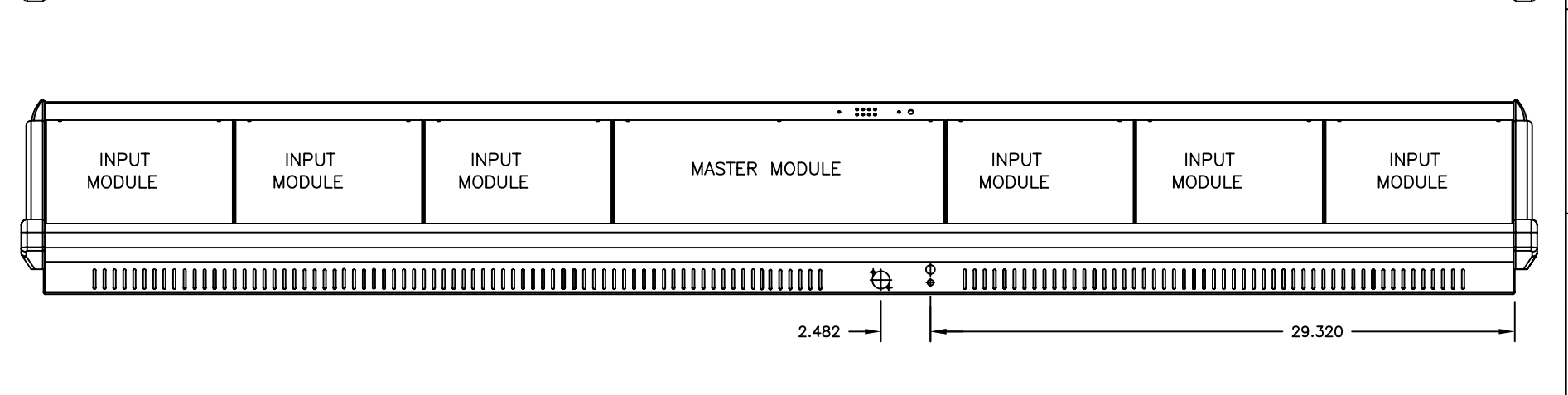
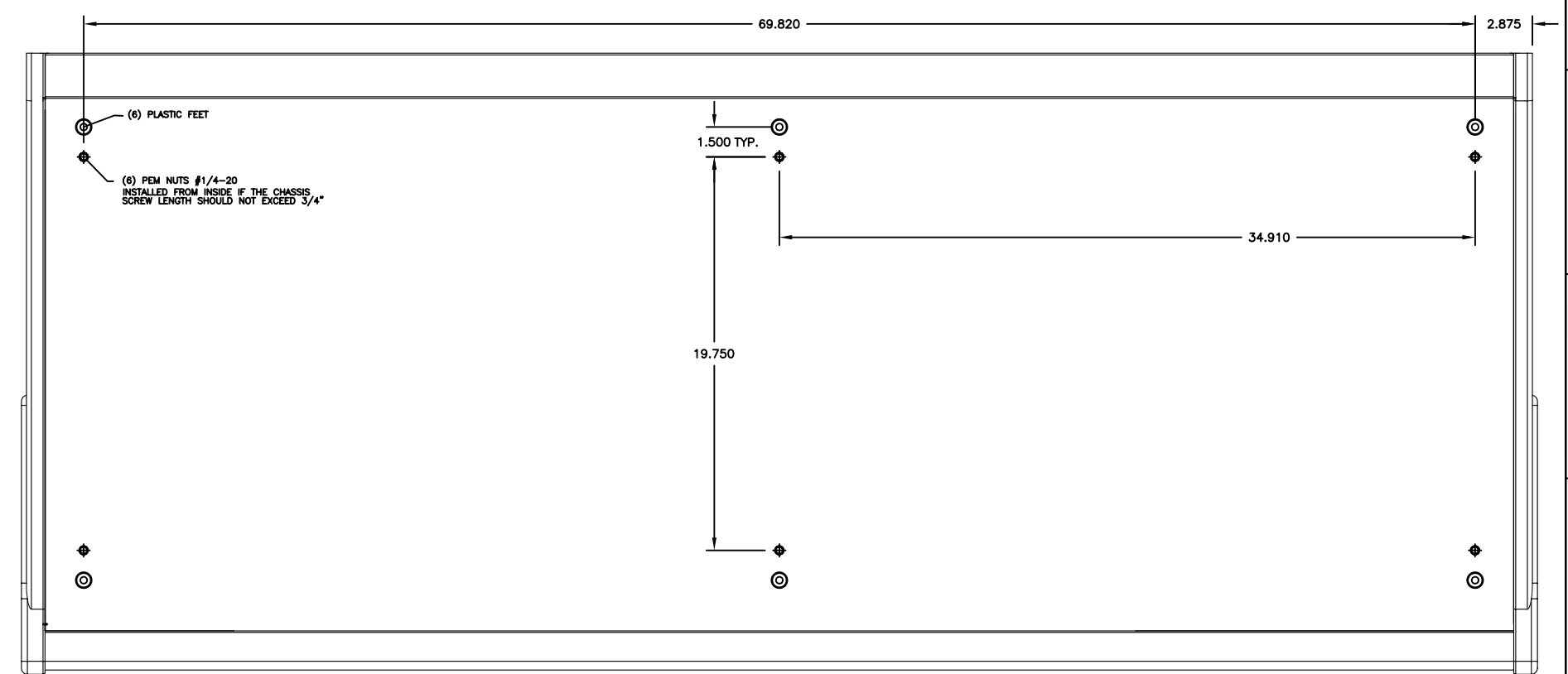
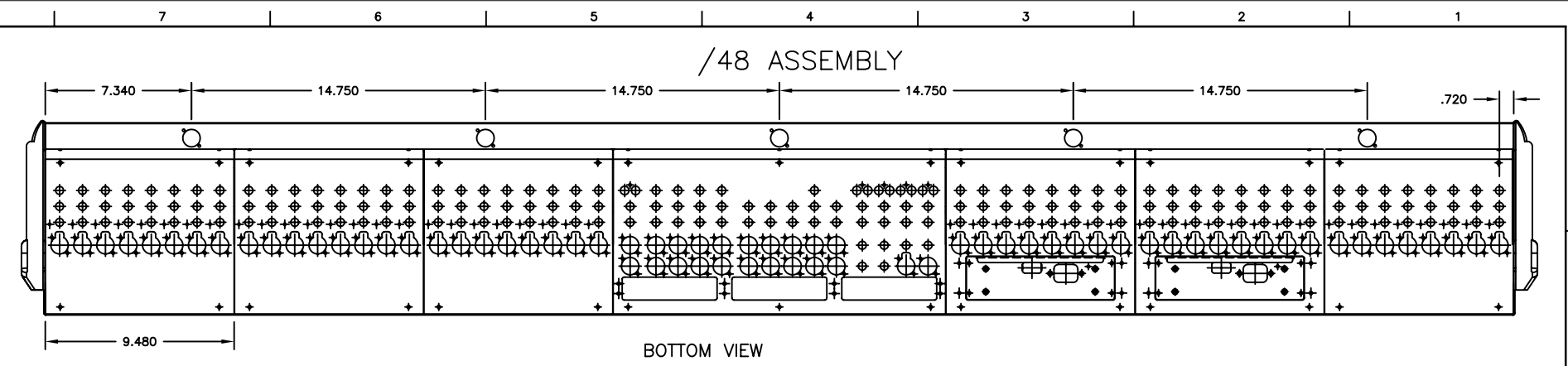
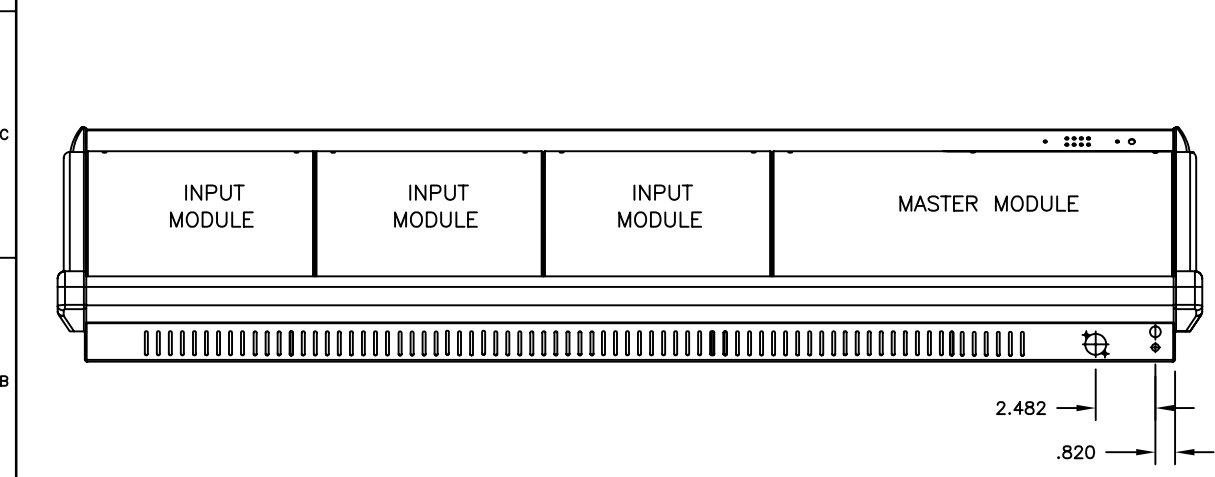
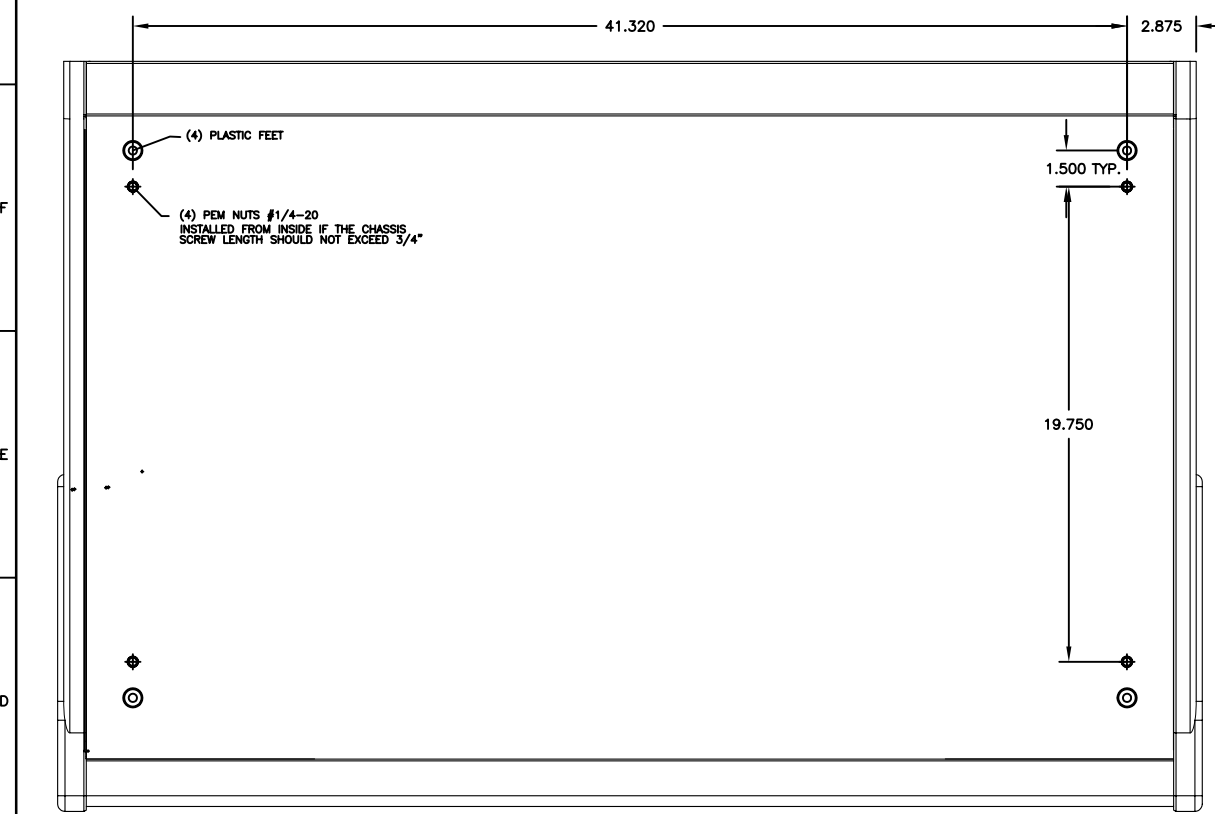
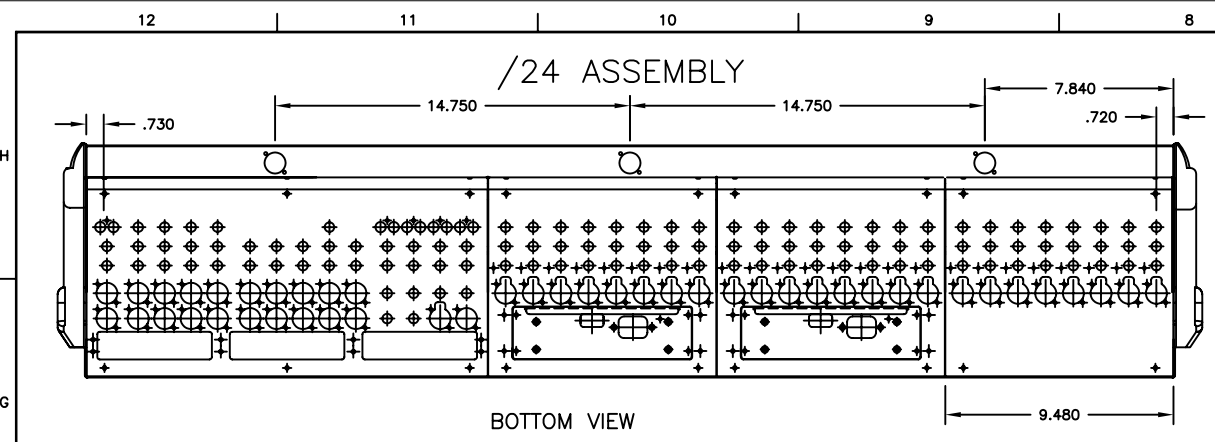

			Title: SPECTRA SERIES CONSOLE CHASSIS ASSEMBLY INFORMATION FOR ROAD CASE DESIGN	
20 West End Road Totowa, NJ 07512			APB P/N:	
Dr.By: OG	Date: 04/20/05	Scale:		
Chk.By:	Date:	DO NOT SCALE DRAWING		
App.By:	Date:	Dwg#: 4D0118		Rev.: C
Tolerance: .XX: +/- .02 .XXX: +/- .01 <+/- .1"	Material:	Finish:	Sheet: 4 OF 5	

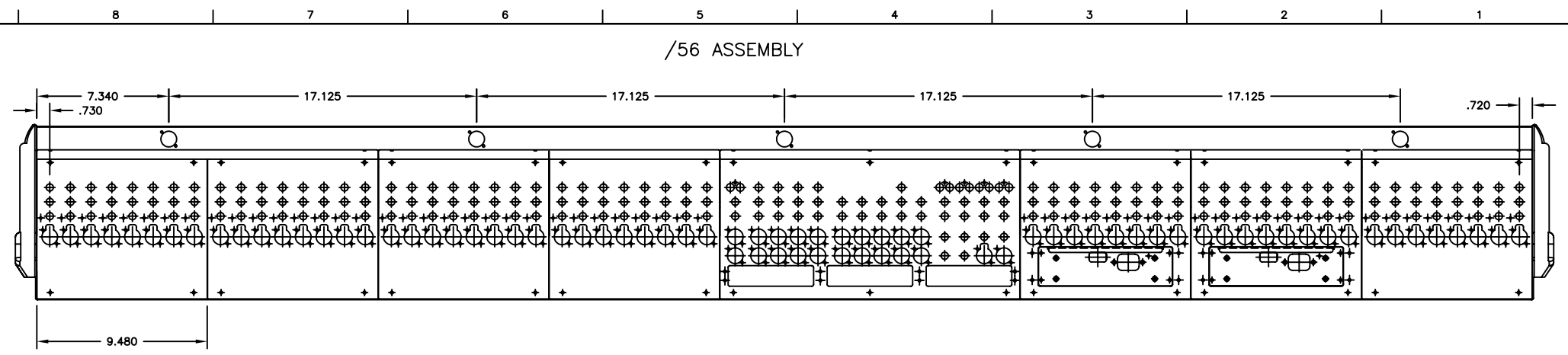
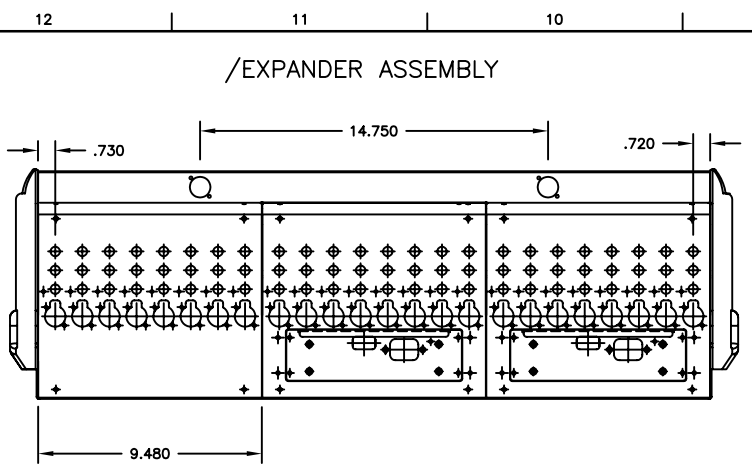

BOTTOM VIEW

BOTTOM VIEW

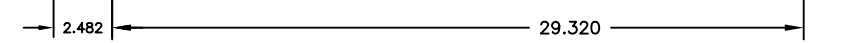
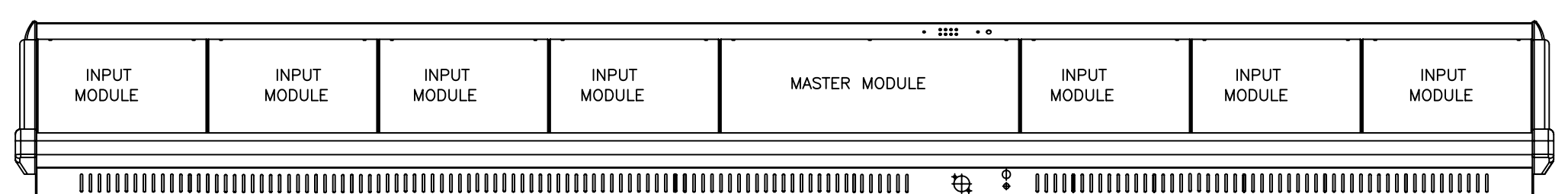
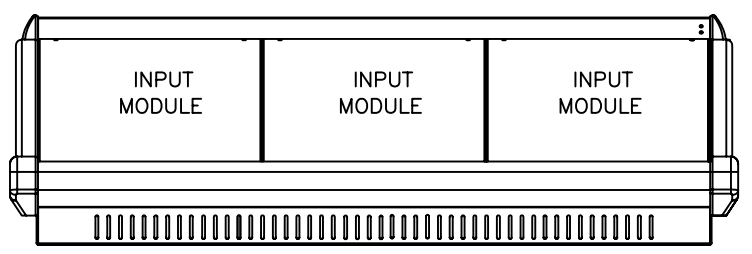
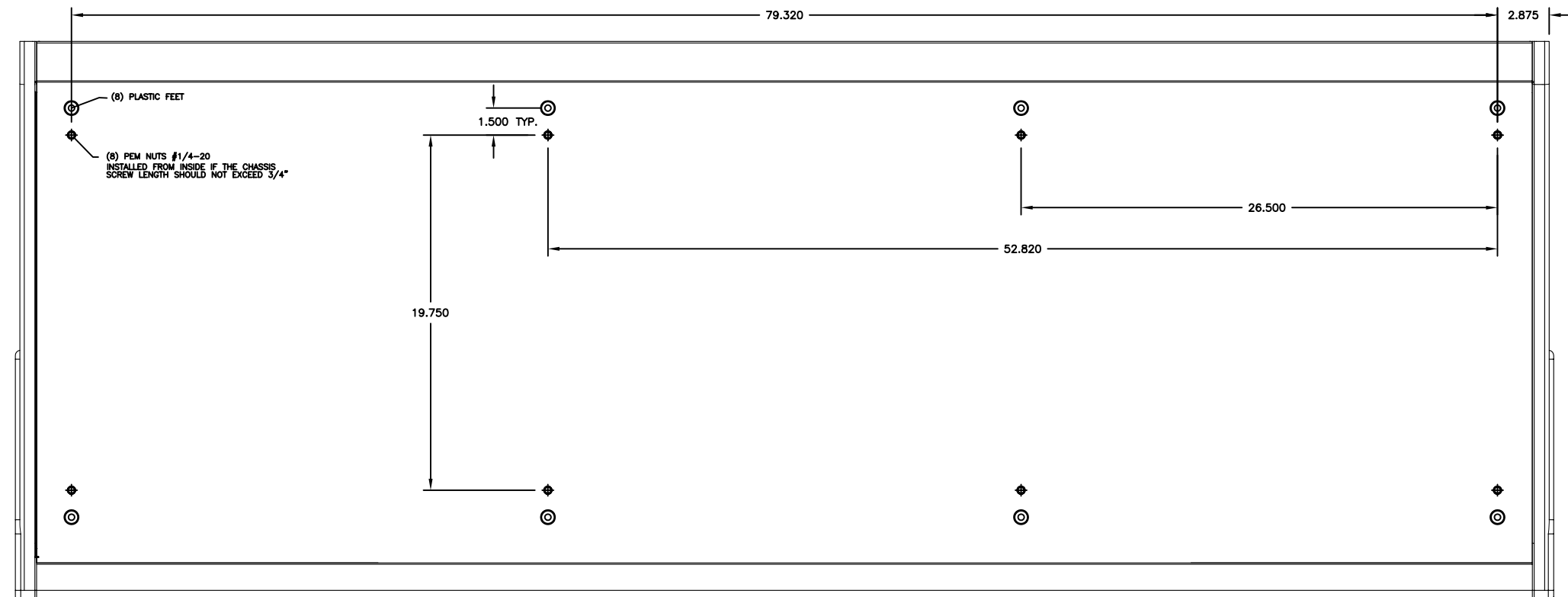
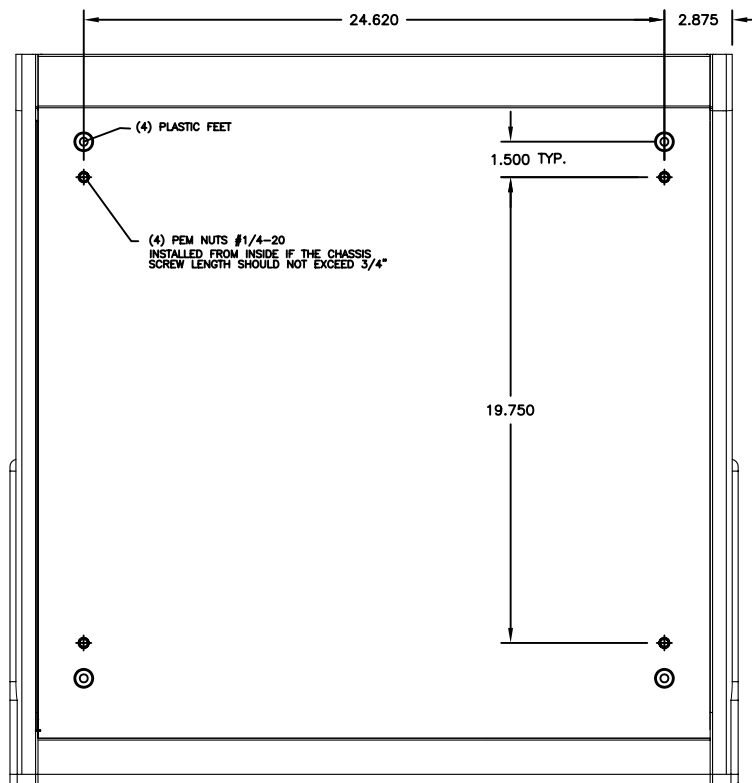

			Title: SPECTRA SERIES CONSOLE CHASSIS ASSEMBLY INFORMATION FOR ROAD CASE DESIGN	
20 West End Road Totowa, NJ 07512 Dr.By: OG Date: 04/20/05 Chk.By: Date: App.By: Date: Tolerance: .XX: +/- .02 XXX: +/- .01 <+/- .1"	APB P/N: Scale: DO NOT SCALE DRAWING Finish:	Dwg#: 4D0118	Rev.: C	Sheet: 5 OF 5